

CHASSIS TRAK IDENTIFICATION LABEL LOCATED ON THE BACK SIDE OF STATIONARY SECTION

INTERMEDIATE SECTION MUST BE INSERTED INTO THE STATIONARY SECTION BEFORE THE END BRACKET IS ATTACHED

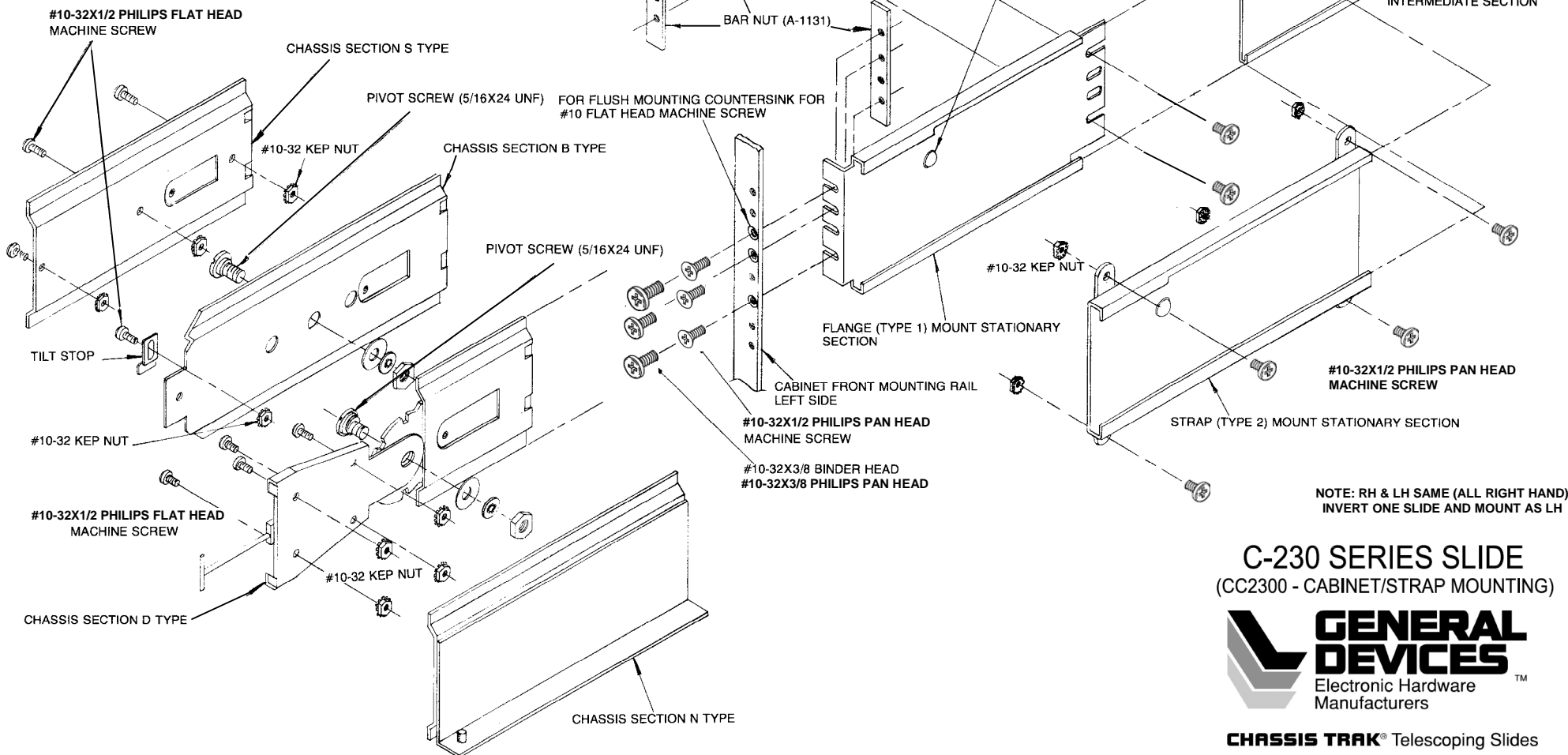

C-230 SERIES SLIDE
(CC2300 - CABINET/STRAP MOUNTING)



CHASSIS TRAK® Telescoping Slides

www.generaldevices.com

INST2300-A

If you have questions please call 317-897-7000
or send e-mail to sales@generaldevices.com